

KEITHLEY

4500-MTS Modular Test System Mainframe User's Manual

A GREATER MEASURE OF CONFIDENCE

WARRANTY

Keithley Instruments, Inc. warrants this product to be free from defects in material and workmanship for a period of 1 year from date of shipment.

Keithley Instruments, Inc. warrants the following items for 90 days from the date of shipment: probes, cables, rechargeable batteries, diskettes, and documentation.

During the warranty period, we will, at our option, either repair or replace any product that proves to be defective.

To exercise this warranty, write or call your local Keithley representative, or contact Keithley headquarters in Cleveland, Ohio. You will be given prompt assistance and return instructions. Send the product, transportation prepaid, to the indicated service facility. Repairs will be made and the product returned, transportation prepaid. Repaired or replaced products are warranted for the balance of the original warranty period, or at least 90 days.

LIMITATION OF WARRANTY

This warranty does not apply to defects resulting from product modification without Keithley's express written consent, or misuse of any product or part. This warranty also does not apply to fuses, software, non-rechargeable batteries, damage from battery leakage, or problems arising from normal wear or failure to follow instructions.

THIS WARRANTY IS IN LIEU OF ALL OTHER WARRANTIES, EXPRESSED OR IMPLIED, INCLUDING ANY IMPLIED WARRANTY OF MERCHANTABILITY OR FITNESS FOR A PARTICULAR USE. THE REMEDIES PROVIDED HEREIN ARE BUYER'S SOLE AND EXCLUSIVE REMEDIES.

NEITHER KEITHLEY INSTRUMENTS, INC. NOR ANY OF ITS EMPLOYEES SHALL BE LIABLE FOR ANY DIRECT, INDIRECT, SPECIAL, INCIDENTAL OR CONSEQUENTIAL DAMAGES ARISING OUT OF THE USE OF ITS INSTRUMENTS AND SOFTWARE EVEN IF KEITHLEY INSTRUMENTS, INC., HAS BEEN ADVISED IN ADVANCE OF THE POSSIBILITY OF SUCH DAMAGES. SUCH EXCLUDED DAMAGES SHALL INCLUDE, BUT ARE NOT LIMITED TO: COSTS OF REMOVAL AND INSTALLATION, LOSSES SUSTAINED AS THE RESULT OF INJURY TO ANY PERSON, OR DAMAGE TO PROPERTY.



Keithley Instruments, Inc.

28775 Aurora Road • Cleveland, Ohio 44139 • 440-248-0400 • Fax: 440-248-6168
1-888-KEITHLEY (534-8453) • www.keithley.com

Sales Offices:

BELGIUM:	Bergensesteenweg 709 • B-1600 Sint-Pieters-Leeuw • 02-363 00 40 • Fax: 02/363 00 64
CHINA:	Yuan Chen Xin Building, Room 705 • 12 Yumin Road, Dewai, Madian • Beijing 100029 • 8610-8225-1886 • Fax: 8610-8225-1892
FINLAND:	Tietäjantie 2 • 02130 Espoo • Phone: 09-54 75 08 10 • Fax: 09-25 10 51 00
FRANCE:	3, allée des Garays • 91127 Palaiseau Cédex • 01-64 53 20 20 • Fax: 01-60 11 77 26
GERMANY:	Landsberger Strasse 65 • 82110 Germering • 089/84 93 07-40 • Fax: 089/84 93 07-34
GREAT BRITAIN:	Unit 2 Commerce Park, Brunel Road • Theale • Berkshire RG7 4AB • 0118 929 7500 • Fax: 0118 929 7519
INDIA:	1/5 Eagles Street • Langford Town • Bangalore 560 025 • 080 212 8027 • Fax: 080 212 8005
ITALY:	Viale San Gimignano, 38 • 20146 Milano • 02-48 39 16 01 • Fax: 02-48 30 22 74
JAPAN:	New Pier Takeshiba North Tower 13F • 11-1, Kaigan 1-chome • Minato-ku, Tokyo 105-0022 • 81-3-5733-7555 • Fax: 81-3-5733-7556
KOREA:	2FL., URI Building • 2-14 Yangjae-Dong • Seocho-Gu, Seoul 137-888 • 82-2-574-7778 • Fax: 82-2-574-7838
NETHERLANDS:	Postbus 559 • 4200 AN Gorinchem • 0183-635333 • Fax: 0183-630821
SWEDEN:	c/o Regus Business Centre • Frosundaviks Allé 15, 4tr • 169 70 Solna • 08-509 04 600 • Fax: 08-655 26 10
TAIWAN:	13F-3. No. 6, Lane 99 Pu-Ding Road • Hsinchu, Taiwan, R.O.C. • 886-3-572-9077 • Fax: 886-3-572-9031

4500-MTS Modular Test System Mainframe User's Manual

Microsoft® Windows, Microsoft® Excel, and Visual Basic®
are either registered trademarks or trademarks of
Microsoft® Corporation in the United States and/or other countries.

©2003, Keithley Instruments, Inc.
All rights reserved.
Cleveland, Ohio, U.S.A.
First Printing, March 2003
Document Number: 4500MTS-900-01 Rev. A

Manual Print History

The print history shown below lists the printing dates of all Revisions and Addenda created for this manual. The Revision Level letter increases alphabetically as the manual undergoes subsequent updates. Addenda, which are released between Revisions, contain important change information that the user should incorporate immediately into the manual. Addenda are numbered sequentially. When a new Revision is created, all Addenda associated with the previous Revision of the manual are incorporated into the new Revision of the manual. Each new Revision includes a revised copy of this print history page.

Revision A (Document Number 4500MTS-900-01) March 2003

Model 4500-MTS Mainframe Specifications

DESCRIPTION

The 4500-MTS is a fully integrated, instrument grade industrial computer with the following features:

- Total of 10 PCI slots, 9 PCI instrument slots available to user. 1 ISA instrument slot. 1 PICMG CPU slot.
- Sideband/trigger bus for cross-card measurement synchronization. Dedicated connector on each instrument slot.
- High-power, low-noise instrument grade power supply. Dedicated connector on each instrument slot.
- Embedded PC with Windows operating system.
- SVGA interface for driving an external monitor.
- 10/100 Base-T LAN interface.
- USB interface.
- RS-232 interface.
- Printer interface.
- Hard disk drive.
- CD-RW disk drive with software.
- Floppy disk drive.
- Steel chassis with enhanced cooling, painted cover, and plastic front bezel.
- Optional integrated Flat Panel Display.
- Full size keyboard with integrated pointing device.

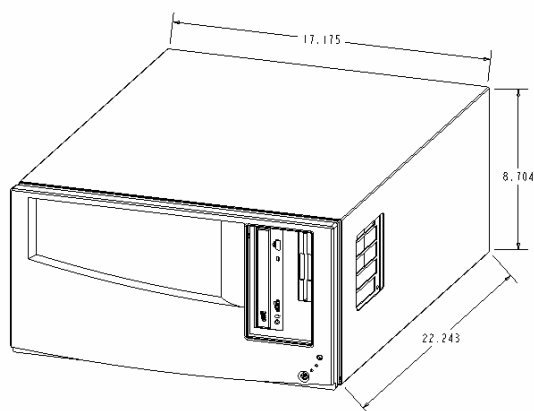

4500-MTS/C

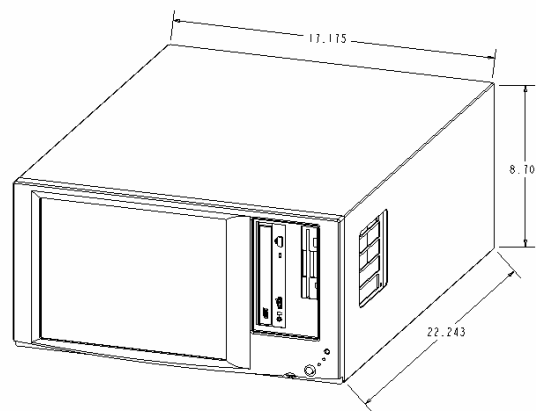

4500-MTS/F

ACCESSORIES:

The following instruments were specifically designed for use with the 4500-MTS mainframe:

- 4501-QIVC – 1A, Quad IV instrument card.
- 4500-QIVC – 500mA, Quad IV instrument card.

The following is a current list of Keithley products that have been validated with the 4500-MTS:

- KPCI-PIO32IOA and KPCI-PDISO8A (16I/16O and 8I/8O Isolated Digital IO)
- KPCI-3130 and KPCI-3132 (8 and 2 channel Analog Output)
- KPCI-3110 (1.25MHz Multi function AIO PCI Card)
- KPCI-3116 (250kHz Low Gain AIO PCI Card)
- KPCI-3108 and KPCI-3107 (100kHz Multi function AIO (3108) AI (3107))
- KPCI-488.2 GPBI PCI Card

Other Keithley PCI and ISA cards could be to be used with the 4500-MTS but have not been verified at the time of this printing.

Model 4500-MTS Mainframe Specifications

SYSTEM BACKPLANE:

PCI

Slots: Ten total. Nine slots are available for PCI instrumentation. One slot reserved.

Compliance: PCI 2.1 – 2.3 (Determined by embedded PC).

ISA

Slots: 1, 16 bit slot.

Compliance: PICMG 2.0

PCI/ISA

Slots: 1

Compliance: PICMG 2.0

SIDEBAND/TRIGGER BUS

Reserved for use by 45XX instrument cards.

SYSTEM POWER SUPPLIES:

The 4500-MTS mainframe utilizes 2 power supplies. The ATX power supply provides power to the computer components (e.g. embedded PC, disk drives, etc...) and PCI bus. The Analog power supply provides 48V power to 45XX instrument card output stages.

ATX Power Supply: 70Watts Max.

Output Voltage (Max Current): +3.3V (14 Amps), +5V (20 Amps), -5V (0.3 Amps), +12V (6 Amps), -12V (0.8 Amps).

Analog Power Supply: +48V (16 Amps max).

EMBEDDED PC:

FEATURES:

Processor: Intel Pentium 4, 2 GHz.

Chipset: Intel 845.

Memory: Up to 2 GB, 200/266 MHz DDR SDRAM on two 184-pin DIMM sockets.

Video: ATI Mobility M6 graphics controller, 16 Mbytes 200 MHz DDR SDRAM display cache. Flat panel LVDS support and simultaneous SVGA support.

LAN: 10/100 Base-T. RJ-45 connector on option card retaining bracket.

USB: One port on option card retaining bracket. (Type 2)

Serial: One port, 9 pin, COM1.

Parallel: One port, 25 pin.

IDE: Two EIDE ports with ULTRA DMA 33/66/100 support.

Floppy: One port.

Keyboard/Mouse: One 9-pin DIN connector on option card retaining bracket. Y-cable provided.

DISK DRIVES:

Hard drive: Interface - EIDE; Capacity - 40 GB.

Floppy disk: Size - 3.5"; Capacity - 1.44 MB.

CD-RW: Interface - ATAPI, EIDE.

CHASSIS:

Material: Stainless steel inner chassis and rear panel. Painted steel cover.

Fan: High reliability cooling fan.

Model 4500-MTS Mainframe Specifications

GENERAL SPECIFICATIONS

POWER SUPPLY:

Power Per Slot Max: 96W for 48V; 8.75W for ATX.

Mains: Push Button ON/OFF switch/fuse/power module combo.

TEMPERATURE:

Operating: 0° to +40°C (with no accessory cards)

Storage: -15° to 60°C

HUMIDITY:

Operating: 5% to 70% RH, non-condensing

ALTITUDE: Maximum 2000m above sea level. For Internal Use Only.

POWER REQUIREMENTS: 100-240VAC, 50/60Hz.

INPUT POWER RATING: 1kVA max.

WARM UP TIME: 1 hour

REGULATORY COMPLIANCE:

Safety: Conforms to European Union Directive 73/23/EEC, EN61010-1, CAT I.

EMC: Conforms to European Union Directive 89/336/EEC, EN61326-1.

DIMENSIONS: 22.3cm high x 43.6cm wide x 56.5cm deep (8.75in. x 2.17in. x 22.25in.).

WEIGHT (approx.): 26.3kg (58lbs) for base system (excluding multi-channel cards, cables, keyboard, etc).

The following safety precautions should be observed before using this product and any associated instrumentation. Although some instruments and accessories would normally be used with non-hazardous voltages, there are situations where hazardous conditions may be present.

This product is intended for use by qualified personnel who recognize shock hazards and are familiar with the safety precautions required to avoid possible injury. Read and follow all installation, operation, and maintenance information carefully before using the product. Refer to the manual for complete product specifications.

If the product is used in a manner not specified, the protection provided by the product may be impaired.

The types of product users are:

Responsible body is the individual or group responsible for the use and maintenance of equipment, for ensuring that the equipment is operated within its specifications and operating limits, and for ensuring that operators are adequately trained.

Operators use the product for its intended function. They must be trained in electrical safety procedures and proper use of the instrument. They must be protected from electric shock and contact with hazardous live circuits.

Maintenance personnel perform routine procedures on the product to keep it operating properly, for example, setting the line voltage or replacing consumable materials. Maintenance procedures are described in the manual. The procedures explicitly state if the operator may perform them. Otherwise, they should be performed only by service personnel.

Service personnel are trained to work on live circuits, and perform safe installations and repairs of products. Only properly trained service personnel may perform installation and service procedures.

Keithley products are designed for use with electrical signals that are rated Installation Category I and Installation Category II, as described in the International Electrotechnical Commission (IEC) Standard IEC 60664. Most measurement, control, and data I/O signals are Installation Category I and must not be directly connected to mains voltage or to voltage sources with high transient over-voltages. Installation Category II connections require protection for high transient over-voltages often associated with local AC mains connections. Assume all measurement, control, and data I/O connections are for connection to Category I sources unless otherwise marked or described in the Manual.

Exercise extreme caution when a shock hazard is present. Lethal voltage may be present on cable connector jacks or test fixtures. The American National Standards Institute (ANSI) states that a shock hazard exists when voltage levels greater than 30V RMS, 42.4V peak, or 60VDC are present. **A good safety practice is to expect that hazardous voltage is present in any unknown circuit before measuring.**

Operators of this product must be protected from electric shock at all times. The responsible body must ensure that operators are prevented access and/or insulated from every connection point. In some cases, connections must be exposed to potential human contact. Product operators in these circumstances must be trained to protect themselves from the risk of electric shock. If the circuit is capable of operating at or above 1000 volts, **no conductive part of the circuit may be exposed.**

Do not connect switching cards directly to unlimited power circuits. They are intended to be used with impedance limited sources. NEVER connect switching cards directly to AC mains. When connecting sources to switching cards, install protective devices to limit fault current and voltage to the card.

Before operating an instrument, make sure the line cord is connected to a properly grounded power receptacle. Inspect the connecting cables, test leads, and jumpers for possible wear, cracks, or breaks before each use.

When installing equipment where access to the main power cord is restricted, such as rack mounting, a separate main input power disconnect device must be provided, in close proximity to the equipment and within easy reach of the operator.

For maximum safety, do not touch the product, test cables, or any other instruments while power is applied to the circuit under test. ALWAYS remove power from the entire test system and discharge any capacitors before: connecting or disconnecting cables or jumpers, installing or removing switching cards, or making internal changes, such as installing or removing jumpers.

Do not touch any object that could provide a current path to the common side of the circuit under test or power line (earth) ground. Always make measurements with dry hands while standing on a dry, insulated surface capable of withstanding the voltage being measured.



The instrument and accessories must be used in accordance with its specifications and operating instructions or the safety of the equipment may be impaired.

Do not exceed the maximum signal levels of the instruments and accessories, as defined in the specifications and operating information, and as shown on the instrument or test fixture panels, or switching card.

When fuses are used in a product, replace with same type and rating for continued protection against fire hazard.

Chassis connections must only be used as shield connections for measuring circuits, NOT as safety earth ground connections.

If you are using a test fixture, keep the lid closed while power is applied to the device under test. Safe operation requires the use of a lid interlock.

If  or  is present, connect it to safety earth ground using the wire recommended in the user documentation.

The  symbol on an instrument indicates that the user should refer to the operating instructions located in the manual.

The  symbol on an instrument shows that it can source or measure 1000 volts or more, including the combined effect of normal and common mode voltages. Use standard safety precautions to avoid personal contact with these voltages.

The **WARNING** heading in a manual explains dangers that might result in personal injury or death. Always read the associated information very carefully before performing the indicated procedure.

The **CAUTION** heading in a manual explains hazards that could damage the instrument. Such damage may invalidate the warranty.

Instrumentation and accessories shall not be connected to humans.

Before performing any maintenance, disconnect the line cord and all test cables.

To maintain protection from electric shock and fire, replacement components in mains circuits, including the power transformer, test leads, and input jacks, must be purchased from Keithley Instruments. Standard fuses, with applicable national safety approvals, may be used if the rating and type are the same. Other components that are not safety related may be purchased from other suppliers as long as they are equivalent to the original component. (Note that selected parts should be purchased only through Keithley Instruments to maintain accuracy and functionality of the product.) If you are unsure about the applicability of a replacement component, call a Keithley Instruments office for information.

To clean an instrument, use a damp cloth or mild, water based cleaner. Clean the exterior of the instrument only. Do not apply cleaner directly to the instrument or allow liquids to enter or spill on the instrument. Products that consist of a circuit board with no case or chassis (e.g., data acquisition board for installation into a computer) should never require cleaning if handled according to instructions. If the board becomes contaminated and operation is affected, the board should be returned to the factory for proper cleaning/servicing.

Table of Contents

1 Getting Started

Introduction	1-2
General information	1-2
Feature overview	1-2
Specifications	1-2
Warranty information	1-3
Contact information	1-3
Safety symbols and terms	1-3
Unpacking and Inspection	1-3
Optional accessories	1-4
Front panel familiarization	1-5
Rear panel familiarization	1-6

2 Installation

Introduction	2-2
Keyboard and mouse connections	2-2
Card installation	2-3
Cover removal	2-3
Internal configuration	2-4
Installation procedure	2-6
Card removal	2-7
Card configuration	2-7
Mainframe installation considerations	2-7
Line power connection	2-7
Ventilation	2-7
Handling and lifting precautions	2-7

3 Operation

Introduction	3-2
Installed software	3-2
Card software	3-2
Operating system	3-2
Software re-installation	3-2
Line power	3-3
Power requirements	3-3
Connecting to line power	3-3
Power-up procedure	3-3

Basic software operation	3-4
Main desktop	3-4
4500-MTS folder	3-4
Control panel	3-5
System settings	3-5
Performing firmware upgrades	3-6
Ethernet connections	3-7
Connections	3-7
Software configuration	3-7
Connecting peripherals	3-8
Peripheral driver configuration	3-8
Parallel port connections	3-8
Serial port connections	3-9
USB port connections	3-9
External monitor connections	3-10
Card connections	3-10

List of Illustrations

1 Getting Started

Figure 1-1	4500-MTS/F mainframe front panel	1-5
Figure 1-2	4500-MTS mainframe rear panel	1-6

2 Installation

Figure 2-1	Keyboard/mouse connector	2-2
Figure 2-2	Internal mainframe configuration	2-5
Figure 2-3	Card installation	2-6

3 Operation

Figure 3-1	Typical 4500-MTS folder contents	3-4
Figure 3-2	Control panel 4500-MTS configuration window	3-5
Figure 3-3	4500-MTS control panel Firmware Upgrade window	3-6
Figure 3-4	Ethernet connections	3-7
Figure 3-5	Typical parallel port connections	3-8
Figure 3-6	Typical serial port connections	3-9
Figure 3-7	Typical USB port connections	3-9
Figure 3-8	Typical external monitor connections	3-10

List of Tables

2

Installation

Table 2-1	Analog power bus pin definitions	2-4
-----------	--	-----

1

Getting Started

Introduction

This user's manual describes the mainframe used with the 4500 Modular Test System (4500-MTS). After reading this document, the user should be able to perform the following tasks.

- Open up the mainframe (only if necessary to add cards; the unit will be shipped with any ordered card(s) already installed).
- Connect the hardware necessary to operate the mainframe.
- Plug in the mainframe to a power outlet.
- Turn on the power, and operate the mainframe.

General information

Feature overview

The 4500-MTS Modular Test System is intended to provide manufacturers of tunable laser diodes, vertical cavity surface emitting lasers, edge emitting lasers, and Erbium Doped Fiber Amplifiers, with a modular, compact, and cost-effective test platform for current and emerging DC and optical production test requirements. The 4500 mainframe provides for space savings (slot density), reduced cost of test (level of test integration), scalability (flexibility and future test adaptability), and ease of use (configuration, less IEEE address overhead).

Key mainframe features include:

- Ten PCI expansion slots (nine PCI instrumentations slots), one ISA slot, and one PICMG CPU slot.
- Sideband/trigger bus for cross-card measurement synchronization. Dedicated internal connector on each instrument slot.
- Flat panel (FPD) color display (4500-MTS/F only).
- Built in hard drive, CD-R/W, and floppy disk drives.
- High-power, low-noise instrument grade power supply. Dedicated internal connector on each instrument slot.
- Serial, parallel, and USB ports.
- 10/100BaseT Ethernet port.
- SVGA interface for driving an external monitor.
- Keyboard with integrated pointing device (track-ball).
- PC-based architecture.
- Windows® 2000 operating system.
- Stand-alone or remote operation via the ethernet port.

Specifications

Detailed specifications are located at the front of this manual.

Warranty information



Warranty information is located at the front of this manual. Should your Model 4500-MTS require warranty service, contact the Keithley representative or authorized repair facility in your area for further information. When returning the instrument for repair, be sure to fill out and include the service form at the back of this manual to provide the repair facility with the necessary information.

Contact information

Worldwide phone numbers are listed at the front of this manual. If you have any questions, please contact your local Keithley representative or call one of our Application Engineers at 1-800-348-3735 (U.S. and Canada only).

Safety symbols and terms

The following symbols and terms may be found on the instrument or used in this manual:

If  or  is present, connect it to safety earth ground using the wire recommended in the user documentation.

The  symbol on an instrument indicates that the user should refer to the operating instructions located in the manual.

The  symbol on the instrument shows that high voltage may be present on the terminal(s). Use standard safety precautions to avoid personal contact with these voltages.

The **WARNING** heading used in this manual explains dangers that might result in personal injury or death. Always read the associated information very carefully before performing the indicated procedure.

The **CAUTION** heading used in this manual explains hazards that could damage the instrument. Such damage may invalidate the warranty.

Unpacking and Inspection

Inspection for damage

The Model 4500-MTS was carefully inspected electrically and mechanically before shipment. After unpacking all items from the shipping carton, check for any obvious signs of physical damage that may have occurred during transit. Report any damage to the shipping agent immediately. Save the original packing carton for possible future shipment.

Package content

The following items are included with every Model 4500-MTS order:

- Model 4500-MTS with line cord
- Ordered measurement cards already installed and configured
- Software disk
- Product Information CD-ROM that contains PDFs of the 4500-MTS Mainframe and Card Manuals
- Model 4500-MTS Quick Start Guide
- Additional accessories as ordered

Optional accessories

4500 measurement cards

4500 measurement cards are installed when ordered with the mainframe and can also be installed in the field (see [Section 2](#) for installation instructions). Please refer to the mainframe specifications or Keithley web site at www.keithley.com for latest offerings of accessories. Currently, the following cards are available. Check www.keithley.com for updated lists of all cards available.

4500-QIVC

- Programmable three-range (30mA, 100mA, 500mA) current source with programmable voltage clamp, source read-back, and precision voltage measurement ($\pm 6\text{V}$ maximum).
- Programmable $\pm 5\text{V}$ voltage source with source read-back and precision three-range (100 μA , 1mA, 10mA) current measurement.

4501-QIVC

- Programmable three-range (100mA, 300mA, 1A) current source with programmable voltage clamp, source read-back, and precision voltage measurement ($\pm 6\text{V}$ maximum).
- Programmable $\pm 5\text{V}$ voltage source with source read-back and precision three-range (100 μA , 1mA, 10mA) current measurement.

Other supported test cards

The following is a current list of Keithley products that have been validated with the 4500-MTS:

- KPCI-PIO32IOA and KPCI-PDISO8A (16I/16O and 8I/8O isolated digital IO)
- KPCI-3130 and KPCI-3132 (8 and 2 channel analog output)
- KPCI-3110 (1.25MHz Multi-function AIO PCI card)
- KPCI-3116 (250kHz low gain AIO PCI card)
- KPCI-3108 and KPCI-3107 [100kHz Multi-function AIO (3108) AI (3107)]
- KPCI-488.2 GPBI PCI card

Other Keithley PCI and ISA cards could be used with the 4500-MTS but have not been validated at the time of this printing.

Rack mount kit

The 4200-RM-050 rack mount kit can be used to mount the 4500-MTS in a standard 19-inch rack.

Front panel familiarization

Figure 1-1 shows the front panel of the 4500-MTS/F mainframe. The 4500-MTS/C is similar except it has no display.

Figure 1-1
4500-MTS/F mainframe front panel

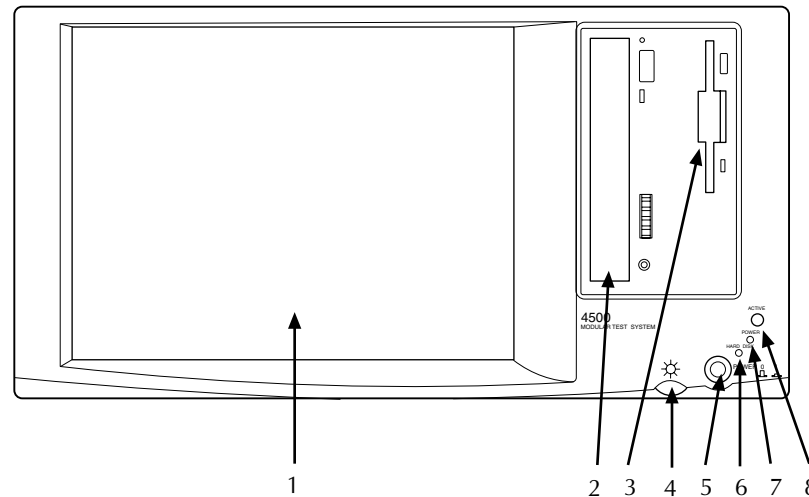

1 Display

Displays graphical user interface, data, graphs, and system operation information (Model 4500-MTS/F only).

2 CD-ROM R/W disk drive

Provides a way to install or update system software, manuals, and utilities. Note that the 4500-MTS provides two IDE ports for support for hard disk and CD-ROM R/W drives.

3 Floppy disk drive

Stores user data.

4 Display brightness

Adjust the display to the desired brightness.

5 POWER switch

Turns main system power on or off (0 = off; 1 = on).

6 HARD DISK indicator

Turns on when the internal hard disk is being accessed.

7 POWER indicator

Turns on when unit power is on.

8 ACTIVE indicator

For future use.

Rear panel familiarization

Figure 1-2 shows the rear panel of the 4500-MTS mainframe. See Section 2 for details on card installation and Section 3 for comprehensive operation information, including peripheral connections and configuration.

Figure 1-2
4500-MTS mainframe rear panel

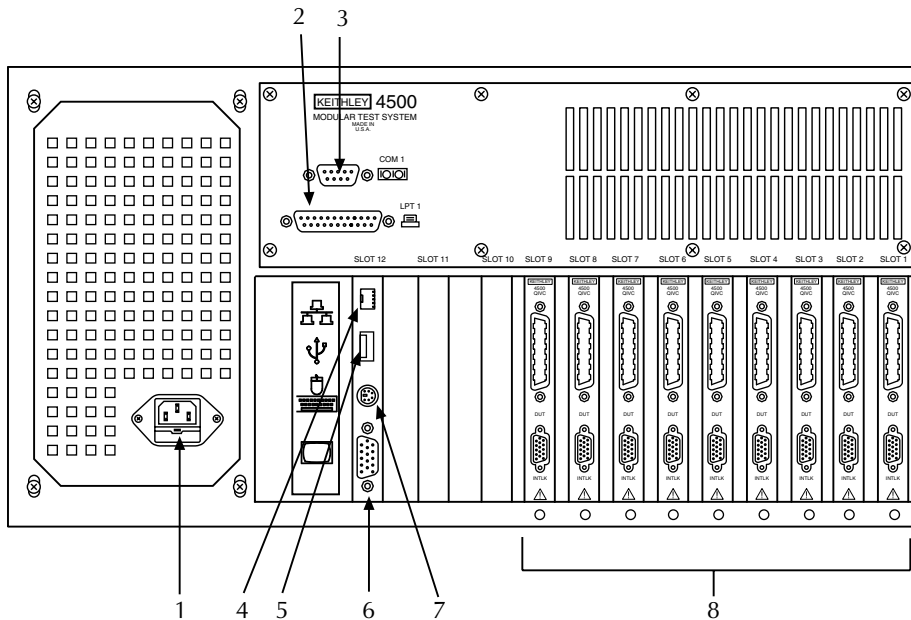

1 Line power connection

Connects the 4500-MTS mainframe to line power (100-240V AC, 50 or 60Hz). Connect only to a grounded outlet using the supplied line cord or the equivalent.

2 Parallel port (LPT1)

Connects the 4500-MTS to the parallel port of a printer and is assigned as LPT1.

3 Serial port (COM1)

Connects the 4500-MTS to the serial port of a printer or other peripheral and is assigned as COM1.

4 Ethernet connector

Connects the mainframe to 10/100BaseT Ethernet and is especially useful with the Model 4500-MTS/C.

5 USB port

Use this high-speed USB port to connect the unit to a USB device such as a printer.

6 External video connector

Connects the 4500-MTS to an external computer monitor and is especially useful with the Model 4500-MTS/C, which has no standard display.

7 Keyboard/mouse connector

This PS/2 style connector connects the keyboard and mouse to the mainframe. Use the supplied Y-cable to connect both keyboard and mouse to the same connector.

8 Measurement card slots

The 4500-MTS mainframe is equipped with ten PCI expansion slots (SLOT 1 to SLOT 10). SLOT 1 through SLOT 9 are intended primarily for use with measurement cards (450x-QIVC cards are shown in illustration). Standard PCI cards can also be installed. [Section 2](#) covers card installation; detailed information pertaining to specific cards can be found in documentation included with those cards.

2

Installation

Introduction

This section includes information on installation, including mouse and keyboard connections, internal mainframe configuration, and card installation.

Keyboard and mouse connections

Before using the 4500-MTS, connect the keyboard and mouse to the corresponding PS/2-style connector on the rear panel of the mainframe. Use the supplied Y-cable to connect both at the same time. [Figure 2-1](#) shows the connector location.

Figure 2-1
Keyboard/mouse connector

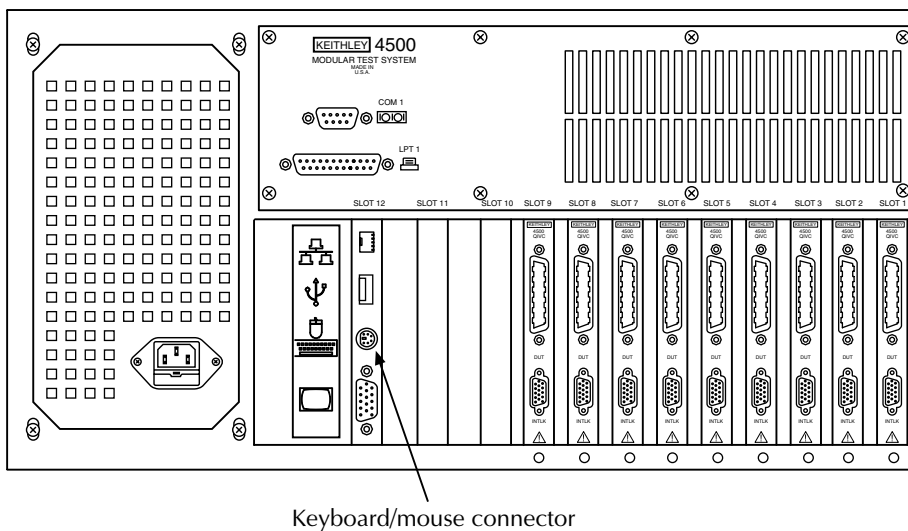

Card installation

WARNING The following information is intended only for qualified service personnel. Do not attempt these procedures unless you are qualified to do so. Some of these procedures may subject you to electric shock, possibly causing personal injury or death.

NOTE *The 4500-MTS mainframe is shipped from the factory with ordered measurement cards already installed. The following procedure is intended for those who wish to install additional cards in the field.*

Cover removal

WARNING Disconnect the line cord and all other cables from the mainframe before removing the cover.

To remove the case cover:

1. Remove the screws on the bottom of the chassis that secure the cover to the case.
2. Carefully remove the cover from the case by sliding it off the top of the chassis.
3. Remove screws that secure the flat top chassis plate underneath, then remove the plate to gain access to components.

WARNING The safety shield that covers the fan and front area should not be removed for card installation/removal or cover removal, and it should be removed only for servicing. Hazardous voltages will be exposed when the shield is removed. Rotating fan blades can cause minor cuts or injury. Keep hands clear when servicing.

4. To re-install, install the top cover plate with the screws, place the cover on the case, then attach it with the screws that were removed in step 1.

WARNING Do not attempt to operate the mainframe with the covers removed.

Internal configuration

Figure 2-2 shows the internal configuration of the mainframe. The major components are outlined below.

NOTE *The exact internal configuration may be slightly different depending on hardware revision level.*

ISA bus

Two ISA bus slots are included, one of which is a shared ISA/PCI slot, while the other slot is ISA-only.

PCI bus

Nine slots are 5V, 33MHz, PCI 2.1 – 2.3 local bus interface slots, and they are intended primarily for use with 4500 measurement cards, but standard 5V PCI cards for other purposes can also be installed.

NOTE *3.3V PCI cards can also be used. 3.3V PCI cards must be placed in opposite direction, and the entire bridge (4 slots) will be 3.3V powered. 3.3V operation cannot be configured on an individual slot basis.*

Trigger bus

This bus is available only for use with 4500 PCI cards. It synchronizes the 4500 PCI cards by using a triggering protocol.

Analog power bus

Each of the nine PCI expansion slots also has an analog power bus that is used to supply power to the 4500 measurement cards. The connection pin layout of the analog power bus is shown in Table 2-1.

Table 2-1
Analog power bus pin definitions

Pin	Description	Pin	Description	Pin	Description
1	NC	10	GND	19	NC
2	NC	11	GND	20	NC
3	NC	12	GND	21	+48V
4	NC	13	+48V	22	+48V
5	NC	14	+48V	23	NC
6	NC	15	NC	24	NC
7	NC	16	NC	25	+48V
8	NC	17	+48V	26	+48V
9	NC	18	+48V	—	—

Figure 2-2
Internal mainframe configuration

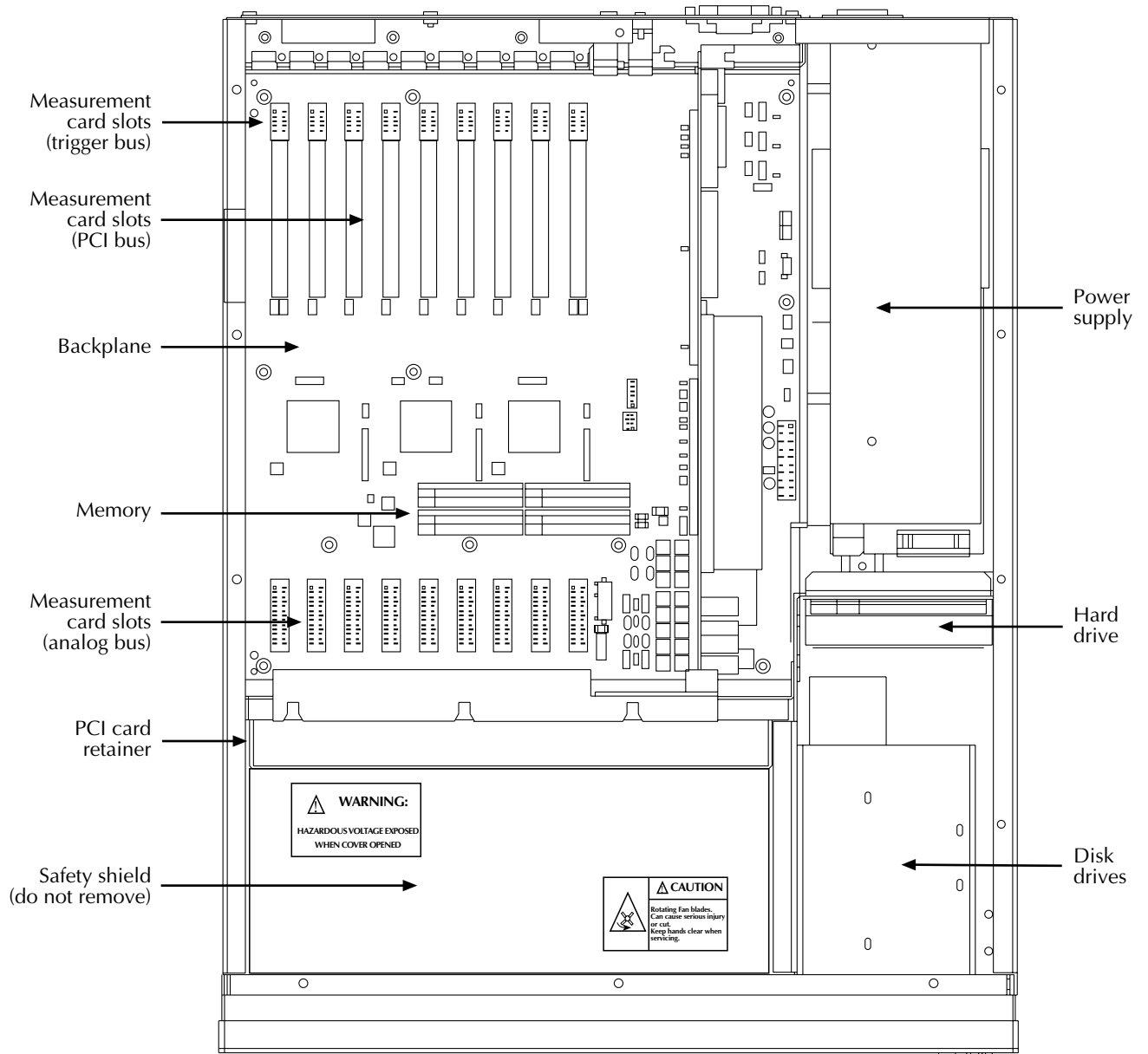

Installation procedure

Install a card using the procedure below and [Figure 2-3](#) as a guide. This procedure assumes that the case cover is already removed as previously discussed.

CAUTION Handle the card only by the edges to avoid contamination that could affect measurement quality. Do not touch PC board traces or edge connector contacts. Use a ground strap and proper grounding techniques to avoid damage caused by static discharge.

1. Remove the cover plate for the slot in which you intend to install the card from the rear panel.
2. Remove the PCI card retainer.
3. Carefully remove the card from its shipping bag.
4. Line up the edge connectors with the slot connectors on the backplane, then carefully insert the card into those connectors. Make sure the card is properly seated in all connectors by applying firm, even pressure to the top edge of the card.
5. Install the screw at the rear panel location to secure the card.
6. Re-install the PCI card retainer.
7. Replace the mainframe top plate and cover.

Figure 2-3
Card installation

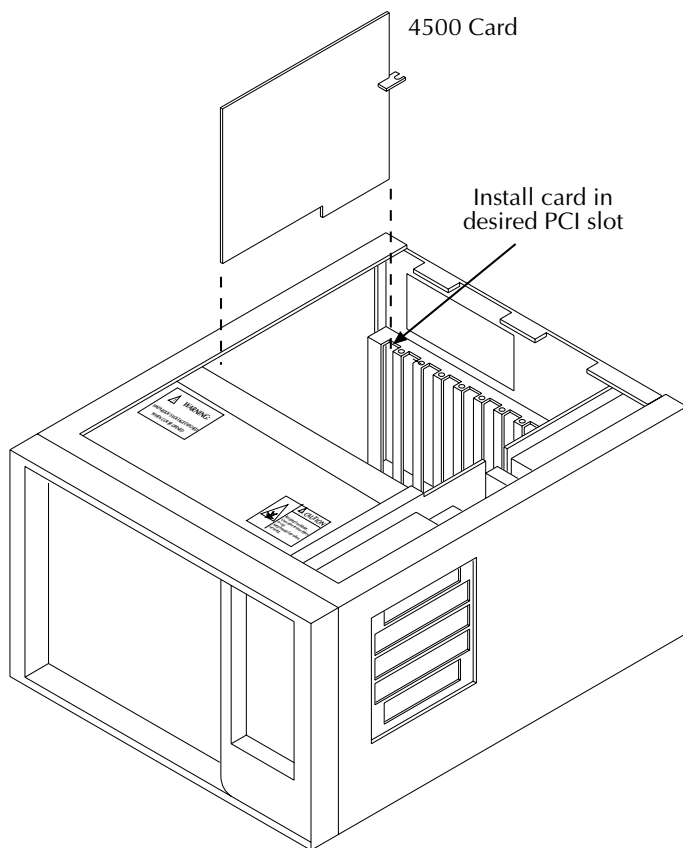

Card removal

To remove a card, first disconnect any cables connected to the card, remove the rear plate screw, and then remove the card from the slot.

Card configuration

The software will automatically recognize and configure the card the next time the mainframe power is turned on. See [Section 3](#) for information.

Mainframe installation considerations

The 4500-MTS mainframe can be operated in various locations such as on a desktop or workbench, or it can be installed in a rack using the optional rack mount kit. However, the following considerations should be taken into account.

Line power connection

To avoid problems caused by fluctuating power, it is strongly recommended that the 4500-MTS be connected to a dedicated 100-240V 50 to 60Hz line power source. In particular, avoid connecting the unit to the same circuit as transient-generating loads, such as large electric motors.

Ventilation

The 4500-MTS mainframe should be operated in a location that provides adequate ventilation to assure adequate cooling. Be especially sure not to block the screened covered air input vents and vertical vents on rear panel. Avoid installing the unit in the same rack with other equipment that generates excessive heat, and allow sufficient clearance above and below heat-generating equipment. In some cases, it may be necessary to install additional forced air rack ventilation.

CAUTION Operating the 4500-MTS without adequate ventilation may cause damage due to overheating, possibly voiding the warranty.

Handling and lifting precautions

WARNING To avoid possible personal injury when moving or lifting the 4500-MTS mainframe, it is recommended that the following precautions be observed:

- Any handling or lifting of the mainframe should be performed by a minimum of two persons.
- The 4500-MTS should be properly supported while it is being secured in a rack. Install the 4500-MTS on a work surface or in a rack with optional rack mount kit.
- Lift the 4500-MTS from the bottom.
- Do not lift from the front bezel.

3

Operation

Introduction

This section contains information on connecting the mainframe to line power, ethernet connections, and connecting peripherals. Basic software information is also included.

Installed software

Card software

The necessary software for any measurement cards that were purchased with the mainframe will already be installed. Software includes:

- **Card driver** — provides the necessary interface between user test programs and the card.
- **Demonstration program** — provides a basic graphical interface to measurement cards to demonstrate their capabilities.
- **Application program examples** — example programs for typical applications intended as a starting point for users to write their own application programs.

Consult the documentation supplied with the measurement card(s) for details.

Operating system

The 4500-MTS mainframe is shipped from the factory with Windows® 2000 already installed. For detailed information on using the operating system, consult the supplied documentation or Windows® 2000 online help.

Software re-installation

Should it become necessary, both card software and operating system can be re-installed from the supplied CD-ROM. Consult the pertinent printed or electronic documentation for installation procedures.

Line power

Power requirements

The 4500-MTS is designed to operate from line power sources in the range of 100 to 240V AC at a line frequency of 50 to 60Hz.

CAUTION Operating the mainframe on line voltages outside this range may result in damage, voiding the warranty.

Connecting to line power

Connect the mainframe to line power as follows:

1. Connect one end of the supplied line cord or the equivalent to the rear panel line power receptacle on the rear panel of the mainframe.
2. Connect the other end of the line cord to a grounded outlet.

WARNING To avoid a possible shock hazard, connect the mainframe only to a grounded outlet using the supplied line cord or the equivalent that has an integral ground wire.

Power-up procedure

Follow these steps to turn on the power:

1. Turn on the power by pressing in on the front panel POWER switch.
2. When the unit is first turned on, the operating system will go through its boot-up sequence in the usual manner.
3. If this is the first time the unit has been powered up since installing a new measurement card, Windows[®] plug-and-play will automatically configure the new hardware, and you may be prompted to click OK to continue, or to insert the appropriate disk if the operating system cannot locate the necessary driver. In either case, follow the instructions on the screen to complete installation.
4. Log into Windows[®] 2000: "User: kiuser", "Password:" <Enter>.
5. Once boot-up and installation are complete, the typical start-up desktop will be displayed.

Basic software operation

A basic overview of supplied software is given below. For complete details on using the software, refer to the card user's manual.

Main desktop

The 4500-MTS icon on the main startup desktop allows access to system facilities such as disk drives, while the 4500-MTS folder accesses the supplied software files.

4500-MTS folder

Figure 3-1 shows the typical contents of the 4500-MTS folder (actual contents may vary, depending on installed cards and software version). Briefly, contents include:

- **Release notes** — includes information on this particular version of 4500-MTS software.
- **Help files** — contains detailed information for using card driver function calls (for the software platforms supported by the 4500-MTS).
- **4500 real-time manager** — the user interface to the 4500 kernel, which runs in the background. The real-time manager is responsible for starting the kernel when the system boots and the user logs in.
- **Reset 4500** — resets the mainframe to default conditions.
- **VB demo app** — Visual Basic® application that demonstrates basic card capabilities.

Figure 3-1
Typical 4500-MTS folder contents

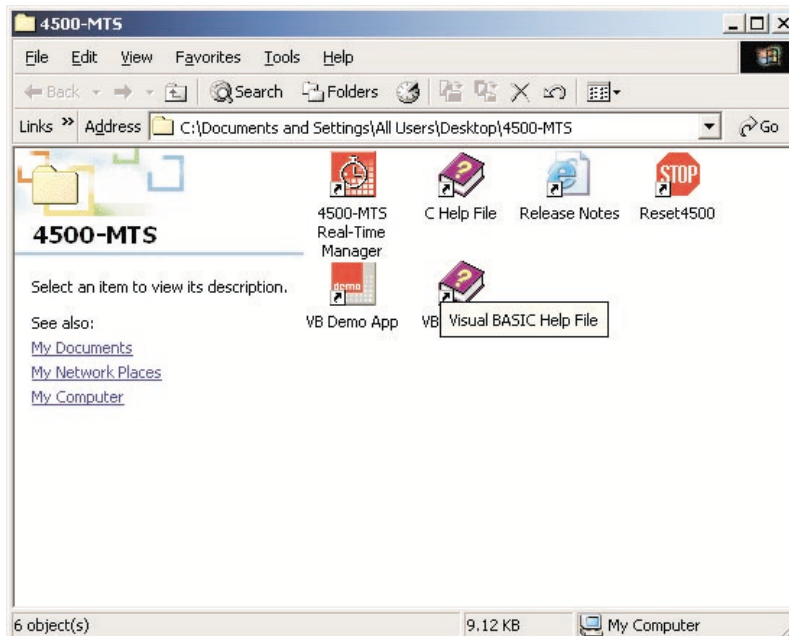

Control panel

To access the control panel, click on **4500-MTS** icon in the Windows[®] Control Panel. **Figure 3-2** shows the control panel. The **System Settings** tab allows you to set line frequency, generate system information, and enable/disable the demo mode. The **Firmware Upgrade** tab allows you to perform system firmware upgrades.

Figure 3-2
Control panel 4500-MTS configuration window

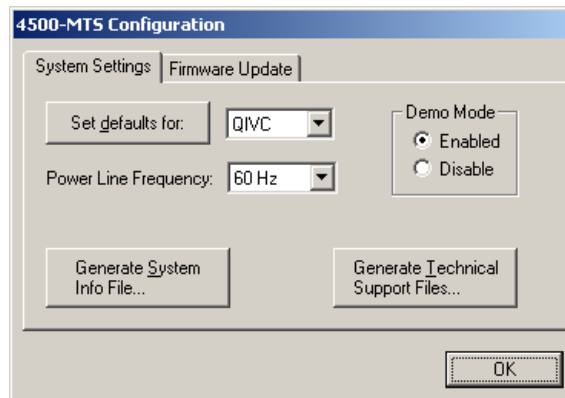

System settings

To change or review system settings, click on the **System Settings** tab in the **4500-MTS Configuration** window (see [Figure 3-2](#)).

Enabling/disabling the demo mode

The demo mode lets you run programs for testing without 4500 cards in your system. Disabling the demo mode allows programs to actually access and control 4500 cards in the system.

To enable or disable the demo mode, click on the **Demo Mode Enabled** or **Disable** selection in the **System Settings** window, and then click **OK**.

Generating system information

To generate information files on system details or for technical support, click on the corresponding button (**Generate System Info File** or **Generate Tech Support Files**). The corresponding information files will be stored on the hard drive in standard ASCII text format for later review.

Setting line frequency

The line frequency setting should be the same as the power line frequency for optimum measurement noise performance. To set the line frequency, click on the **Line Frequency** tab in the **4500-MTS Configuration** window, and then set line frequency to the correct setting and click **OK**.

Setting defaults

Set Defaults will bring up a window to allow you to set up default settings for the selected card. The settings include: Current Source Range, Current Source Voltage Compensation, Current Measurement Range, Current Source Readback State, Voltage Measure State, Voltage Readback State, Current Measure State, and Measurement Speed (NPLC).

Performing firmware upgrades

Firmware upgrades can be performed by clicking on the **Firmware Upgrade** tab (see [Figure 3-3](#)). Follow the instructions included with the upgrade software to complete the upgrade process.

Figure 3-3
4500-MTS control panel Firmware Upgrade window

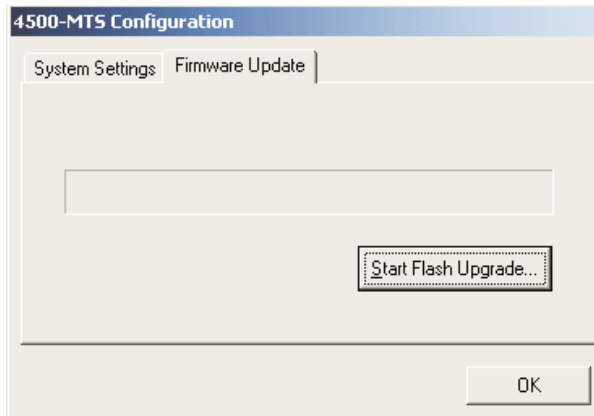

Ethernet connections

Connections

When making Ethernet connections, use only Category 5 UTP cable. Use a straight-through cable for connections to a network wall plate jack, hub, or patch panel. Use a cross over cable for connections directly to another computer. [Figure 3-4](#) shows typical network connections to the 4500-MTS Ethernet jack, which is a standard RJ-45 connector.

Figure 3-4
Ethernet connections

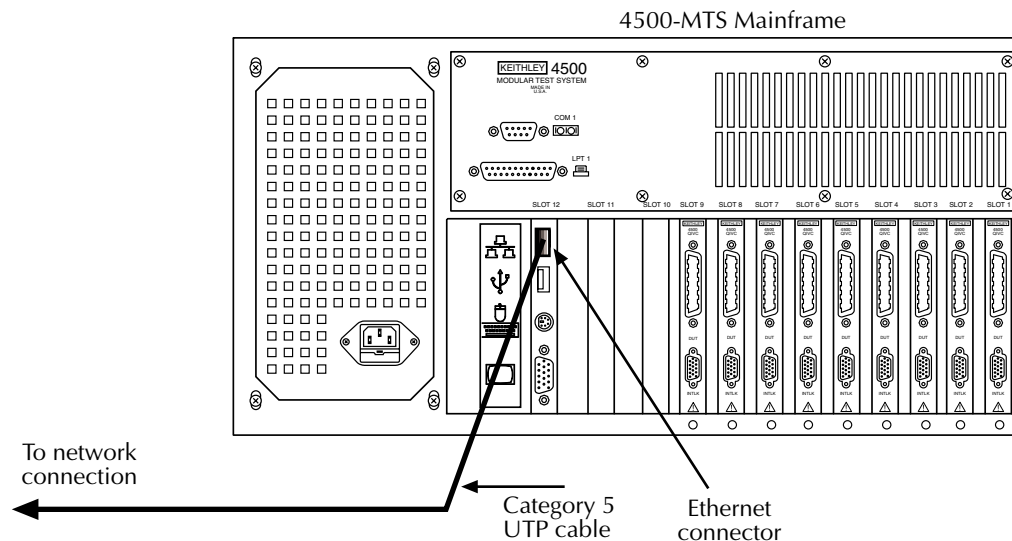

Software configuration

NOTE *The 4500-MTS software should be installed on the external computer on the network prior to software configuration.*

To configure the 4500-MTS for use on a network:

1. Open the Windows[®] Control Panel.
2. Double-click on the **Network and Dial-up Connections** icon.
3. Enter the required IP address, as well as DNS and Gateway (router) information.
4. Click **OK** to complete the process.

Connecting peripherals

Peripheral driver configuration

In most instances, Windows[®] plug-and-play will automatically install the necessary drivers for peripherals connected to the parallel, serial, or USB ports. However, some cases may require user configuration. In general, peripherals can be manually configured as follows:

- For printers, use the **Add Printer** icon in the Printers folder.
- For other hardware use the **Add/Remove Hardware** icon in the Control Panel.

See the Windows[®] and peripheral documentation for details.

Parallel port connections

Typical connections to the parallel port are shown in [Figure 3-5](#). Be sure to use shielded parallel cables to avoid electrical interference that could have detrimental effects on measurement quality.

Figure 3-5
Typical parallel port connections

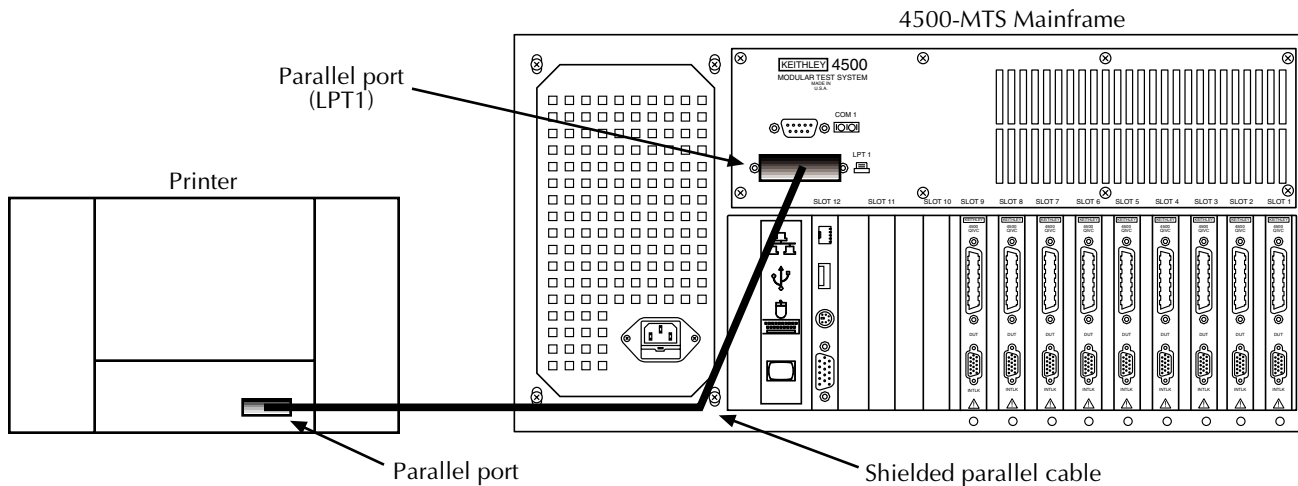

Serial port connections

Typical connections to the serial port are shown in [Figure 3-6](#). Be sure to use a shielded parallel cable such as the Keithley Model 7009 to avoid electrical interference that could have detrimental affects on measurement quality. Note that it may be necessary to set up port parameters such as baud rate, parity, and stop bits under **Properties** for your serial port device.

Figure 3-6
Typical serial port connections

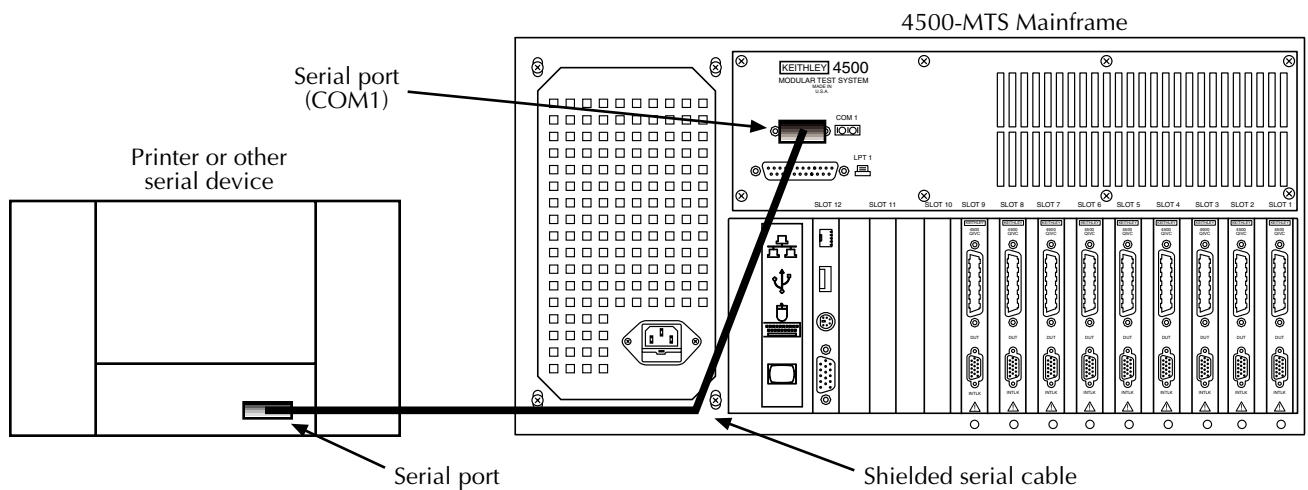

USB port connections

Typical connections to the USB port are shown in [Figure 3-7](#). Use a type A male USB connector to make connections to the 4500-MTS. Use the appropriate connector (A or B) to make connections to the USB peripheral device.

Figure 3-7
Typical USB port connections

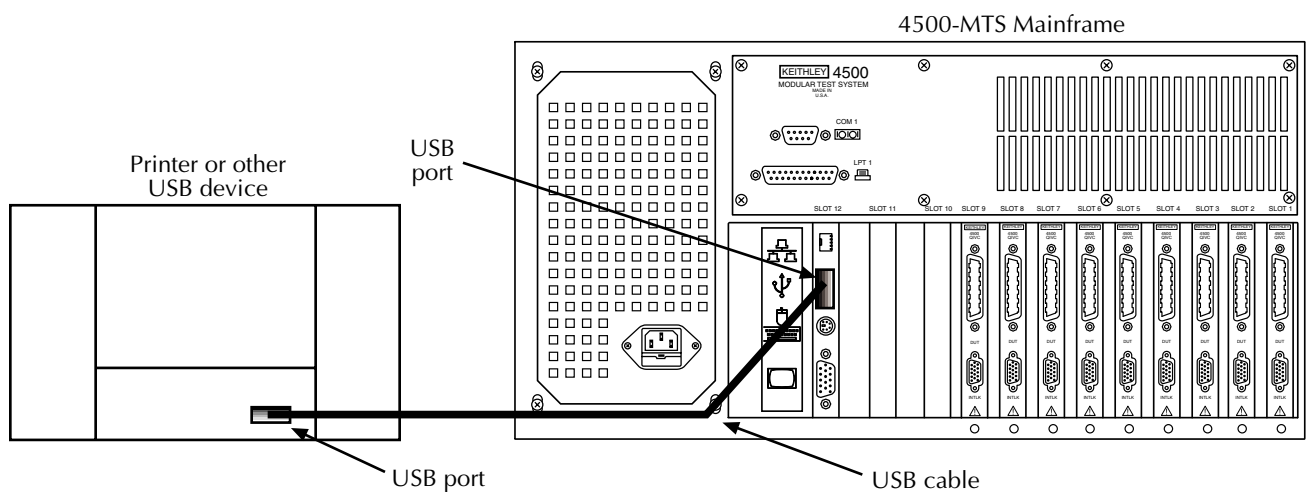

External monitor connections

Typical connections to an external monitor are shown in [Figure 3-8](#). You can set up necessary display properties using the **Control Panel Display** icon or by right-clicking on the main Desktop and then selecting **Properties**.

NOTE *The minimum display resolution for the supplied 4500 Demo Software is 600 × 800.*

Figure 3-8
Typical external monitor connections

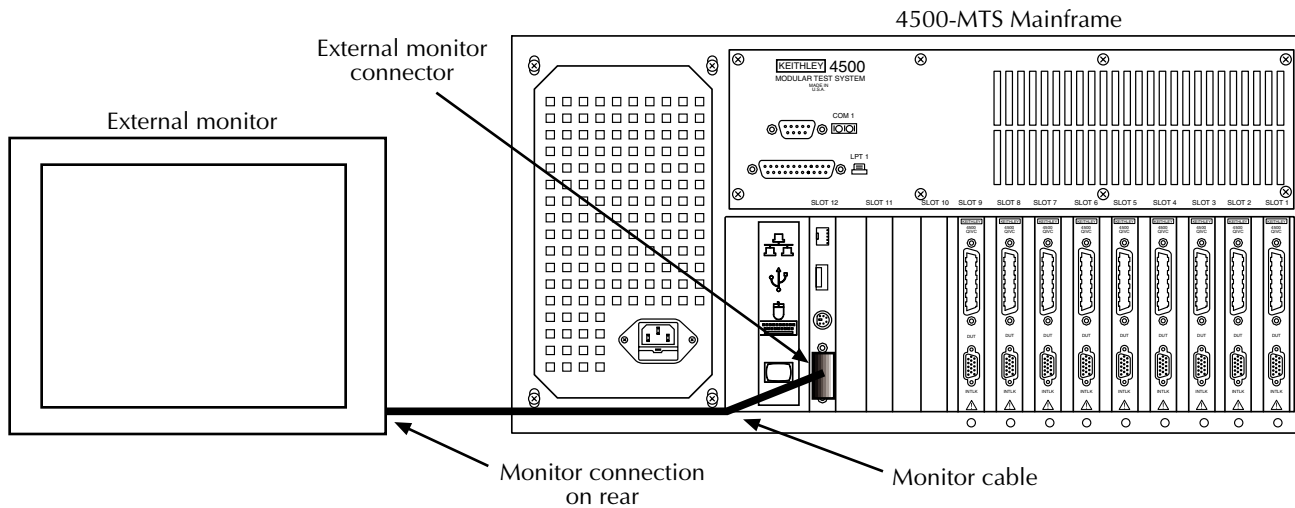

Card connections

Refer to the card documentation for detailed information on card connections. For the 4500-QIVC and 4501-QIVC cards, refer to Section 2 of the 4500-QIVC User's Manual for connections.

Index

Numerics

- 4500 measurement cards 1-4
- 4500-MTS folder 3-4
- 4500-QIVC 1-4
- 4501-QIVC 1-4

B

- Basic software operation 3-4

C

- Card configuration 2-7
- Card connections 3-10
- Card installation 2-3
- Card removal 2-7
- Card software 3-2
- Connecting peripherals 3-8
- Connecting to line power 3-3
- Contact information 1-3
 - Phone number 1-3
- Control panel 3-5
- Cover removal 2-3

E

- Enabling/disabling the demo mode 3-5
- Ethernet connections 3-7
- External monitor connections 3-10

F

- Feature overview 1-2
- Front panel familiarization 1-5

G

- General information 1-2
- Generating system information 3-5
- Getting Started 1-1

H

- Handling and lifting precautions 2-7

I

- Inspection for damage 1-3
- Installation 2-1
- Installation procedure 2-6
- Installed software 3-2
- Internal configuration 2-4
 - Analog power bus 2-4
 - ISA bus 2-4
 - PCI bus 2-4
 - Trigger bus 2-4
- Introduction 1-2, 2-2, 3-2

K

- Keyboard and mouse connections 2-2

L

- Line power 3-3
- Line power connection 2-7

M

- Main desktop 3-4
- Mainframe installation considerations 2-7

O

- Operating system 3-2
- Operation 3-1
- Optional accessories 1-4
- Other supported test cards 1-4

P

- Package content 1-3
- Parallel port connections 3-8
- Performing firmware upgrades 3-6
- Peripheral driver configuration 3-8
- Power requirements 3-3
- Power-up procedure 3-3

R

- Rack mount kit 1-4
- Rear panel familiarization 1-6

S

- Safety symbols and terms 1-3
- Serial port connections 3-9
- Setting defaults 3-5

- Setting line frequency 3-5
- Software configuration 3-7
- Software re-installation 3-2
- Specifications 1-2
- System settings 3-5

U

- Unpacking and Inspection 1-3
- USB port connections 3-9

V

- Ventilation 2-7

W

- Warranty information 1-3



Service Form

Model No. _____ Serial No. _____ Date _____

Name and Telephone No. _____

Company _____

List all control settings, describe problem and check boxes that apply to problem. _____

- | | | |
|--|--|--|
| <input type="checkbox"/> Intermittent | <input type="checkbox"/> Analog output follows display | <input type="checkbox"/> Particular range or function bad; specify _____ |
| <input type="checkbox"/> IEEE failure | <input type="checkbox"/> Obvious problem on power-up | <input type="checkbox"/> Batteries and fuses are OK |
| <input type="checkbox"/> Front panel operational | <input type="checkbox"/> All ranges or functions are bad | <input type="checkbox"/> Checked all cables |

Display or output (check one)

- | | |
|-----------------------------------|--|
| <input type="checkbox"/> Drifts | <input type="checkbox"/> Unable to zero |
| <input type="checkbox"/> Unstable | <input type="checkbox"/> Will not read applied input |
| <input type="checkbox"/> Overload | |

- | | |
|---|--|
| <input type="checkbox"/> Calibration only | <input type="checkbox"/> Certificate of calibration required |
| <input type="checkbox"/> Data required | |

(attach any additional sheets as necessary)

Show a block diagram of your measurement system including all instruments connected (whether power is turned on or not). Also, describe signal source.

Where is the measurement being performed? (factory, controlled laboratory, out-of-doors, etc.)

What power line voltage is used? _____ Ambient temperature? _____ °F

Relative humidity? _____ Other? _____

Any additional information. (If special modifications have been made by the user, please describe.)

Be sure to include your name and phone number on this service form.

Specifications are subject to change without notice.

All Keithley trademarks and trade names are the property of Keithley Instruments, Inc. All other trademarks and trade names are the property of their respective companies.

KEITHLEY

Keithley Instruments, Inc.

28775 Aurora Road • Cleveland, Ohio 44139 • 440-248-0400 • Fax: 440-248-6168
1-888-KEITHLEY (534-8453) • www.keithley.com

Sales Offices: **BELGIUM:** Bergensesteenweg 709 • B-1600 Sint-Pieters-Leeuw • 02-363 00 40 • Fax: 02/363 00 64
CHINA: Yuan Chen Xin Building, Room 705 • 12 Yumin Road, Dewai, Madian • Beijing 100029 • 8610-8225-1886 • Fax: 8610-8225-1892
FINLAND: Tietäjäsentie 2 • 02130 Espoo • Phone: 09-54 75 08 10 • Fax: 09-25 10 51 00
FRANCE: 3, allée des Garays • 91127 Palaiseau Cédex • 01-64 53 20 20 • Fax: 01-60 11 77 26
GERMANY: Landsberger Strasse 65 • 82110 Germering • 089/84 93 07-40 • Fax: 089/84 93 07-34
GREAT BRITAIN: Unit 2 Commerce Park, Brunel Road • Theale • Berkshire RG7 4AB • 0118 929 7500 • Fax: 0118 929 7519
INDIA: 1/5 Eagles Street • Langford Town • Bangalore 560 025 • 080 212 8027 • Fax: 080 212 8005
ITALY: Viale San Gimignano, 38 • 20146 Milano • 02-48 39 16 01 • Fax: 02-48 30 22 74
JAPAN: New Pier Takeshiba North Tower 13F • 11-1, Kaigan 1-chome • Minato-ku, Tokyo 105-0022 • 81-3-5733-7555 • Fax: 81-3-5733-7556
KOREA: 2FL., URI Building • 2-14 Yangjae-Dong • Seocho-Gu, Seoul 137-888 • 82-2-574-7778 • Fax: 82-2-574-7838
NETHERLANDS: Postbus 559 • 4200 AN Gorinchem • 0183-635333 • Fax: 0183-630821
SWEDEN: c/o Regus Business Centre • Frosundaviks Allé 15, 4tr • 169 70 Solna • 08-509 04 600 • Fax: 08-655 26 10
TAIWAN: 13F-3. No. 6, Lane 99 Pu-Ding Road • Hsinchu, Taiwan, R.O.C. • 886-3-572-9077 • Fax: 886-3-572-9031